



## Runner systems for wooden drawers



Technik für Möbel

  
**Hettich**

# Lasting top performance and ultimate convenience: The Quadro principle

Integrated features for a feel of luxury:

- Silent System for gentle closing performance or
- Push to open opening system for purist furniture design

Concealed runner profiles for discerning furniture design

Special Quadro profile geometry for good tracking and stability

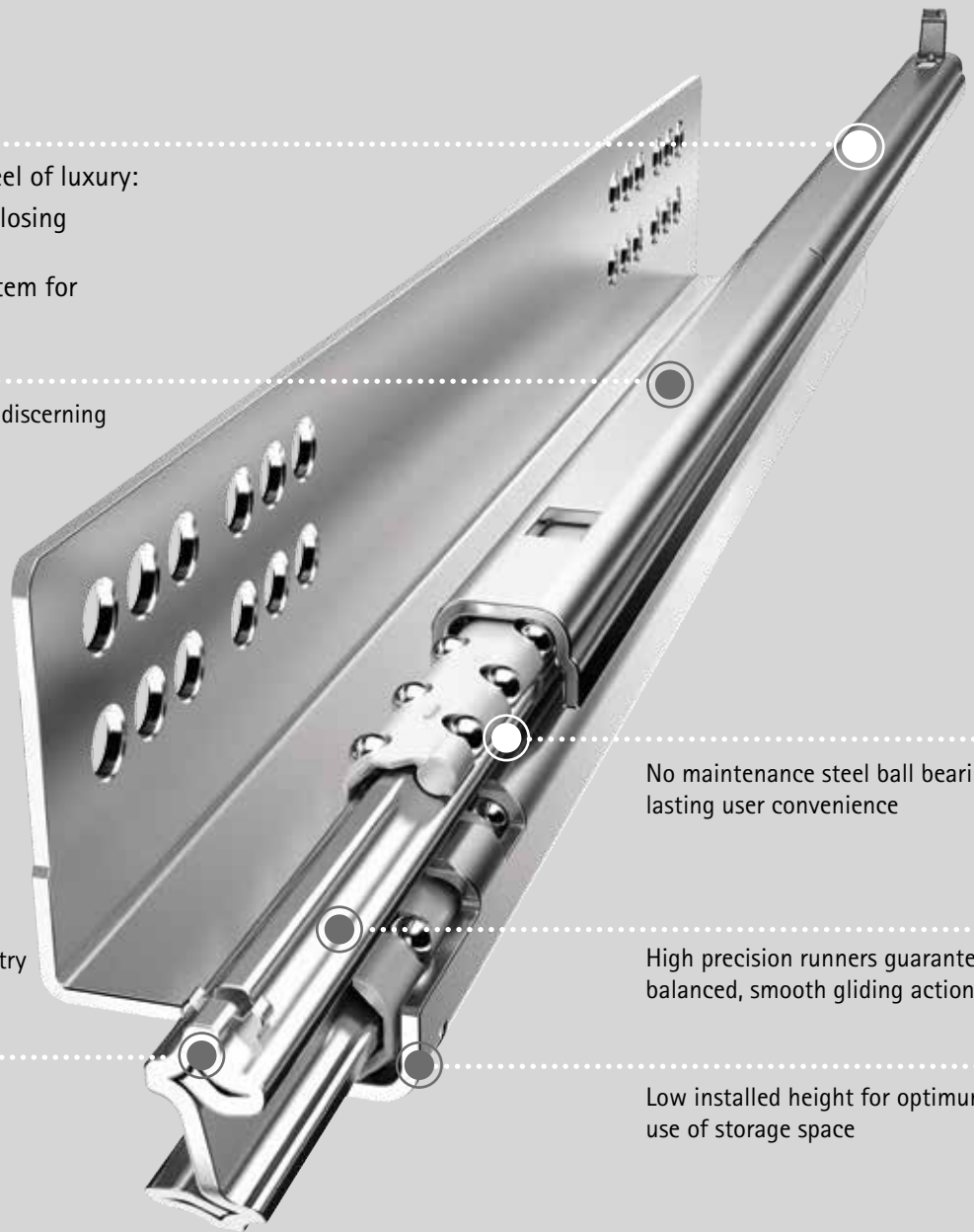

No maintenance steel ball bearings for lasting user convenience

High precision runners guarantee balanced, smooth gliding action

Low installed height for optimum use of storage space

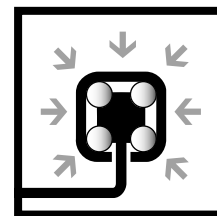

Even heavily laden, Quadro provides easy action and smoothly gliding performance. Forces acting on it are taken up on all sides by the special profile geometry – making sure that Quadro provides maximum vertical and horizontal stability.

## Luxuriously quiet: **Quadro with Silent System**



### **Silent System – perfectly controlled closure!**

Drawers that close gently and quietly add a touch of luxury with a guaranteed feel good factor for any living space. No more loud slamming noises to disturb a harmonious living atmosphere. Silent System means silent and soft closing. Whether small or large, light or heavily laden – the Quadro runner with integrated Silent System gives a feel of luxury to any drawer.

Silent System comes preinstalled with the Quadro runner. This means no additional work at the assembly stage, just a large added portion of luxury and convenience. Give your customers this unique combination of extremely long lasting functionality and the luxury of whisper quiet closure!



## Opening convenience without handles: **Quadro with Push to open**



Purist design is right on trend – and the Push to open function the answer to making handleless design an option on all fronts. With this innovative opening mechanism from Hettich, planning and producing handleless fronts for modern furniture couldn't be easier. Push to open conveniently opens any drawer and pull-out at the mere press of a finger.

Even with both hands full, drawers open and close with utmost ease. Not only that – it also opens up new horizons in designing furniture frontages!

Push to open is integrated in the Quadro runner. Good design can be realised so quickly and so easily.



## Quadro installation

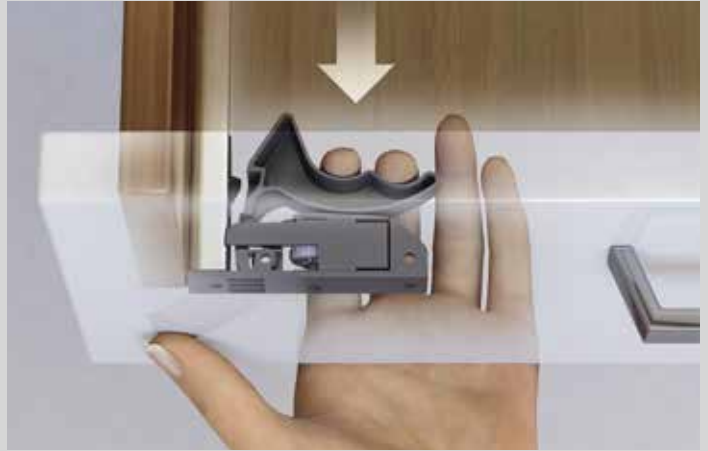

### Slide on installation

The drawer is fitted horizontally on the runners and pushed into place. The catch automatically locks the drawer onto the Quadro for a secure fit.

Unlatching the drawer and removing it from the runners is just as easy. When a defined force is exceeded, the drawer is released without using the catches. This rules out any negative consequences of incorrect removal by end users.

The height adjustment facility integrated in the catch produces perfect front panel alignment – without the need for tools of course.

# Drawer runners for wooden drawers

- ▶ Full extension runner Quadro V6 with Silent System
- ▶ Loading capacity 30 kg



- ▶ **Silent System** - the integrated Silent System closes the drawer quietly and gently
- ▶ Convenient slide on installation with catches and tool-less vertical adjustment
- ▶ Load capacity to EN 15338, Level 3
- ▶ Galvanised steel

## Quadro V6 with Silent System

Nominal length / drawer length NL mm	Minimum carcass depth KT mm	Hole spacing b1 mm	Hole spacing b2 mm	Order no.	
				left 20 ea.	right 20 ea.
300	313	192		9 118 030	9 118 031
320	333	192		9 118 056	9 118 057
350	363	192		9 113 013	9 113 014
380	393	224		9 118 052	9 118 053
400	413	224		9 099 108	9 099 110
420	433	224		9 118 000	9 118 011
450	463	256		9 099 124	9 099 125
480	493	256		9 118 037	9 118 039
500	513	288	224	9 118 058	9 118 059
520	533	288	224	9 117 998	9 117 999
550	563	288	224	9 118 043	9 118 044
580	593	352		9 118 064	9 118 065
600	613	352		9 118 028	9 118 029

Using the mounting plug reduces drawer length (NL) by 10 mm.

## Catch for wooden drawers with grooved bottom panel (Quadro 25 and Quadro V6)



- ▶ For safely connecting the Quadro runner and wooden drawer without the need for tools
- ▶ Infinite height adjustment up to + 2 mm via a knurled wheel
- ▶ Plastic, black

Hinge side of cabinet	Order no.	PU
left	9 144 830	100 ea.
right	9 144 841	100 ea.

# Drawer runners for wooden drawers

- ▶ Full extension runner Quadro V6 with Silent System
- ▶ Loading capacity 30 kg

## Catch for pull-out shelves / wooden drawers with flush bottom panel Quadro V6



- ▶ For securely connecting Quadro runner and pull-out shelf / wooden drawer with flush bottom panel, including mounting, without the need for tools including plug
- ▶ For 16 - 19 mm thick pull-out shelves
- ▶ Plastic, black / white

<b>Order no.</b>	PU
<b>0 075 808</b>	5 pair

## Planning dimensions

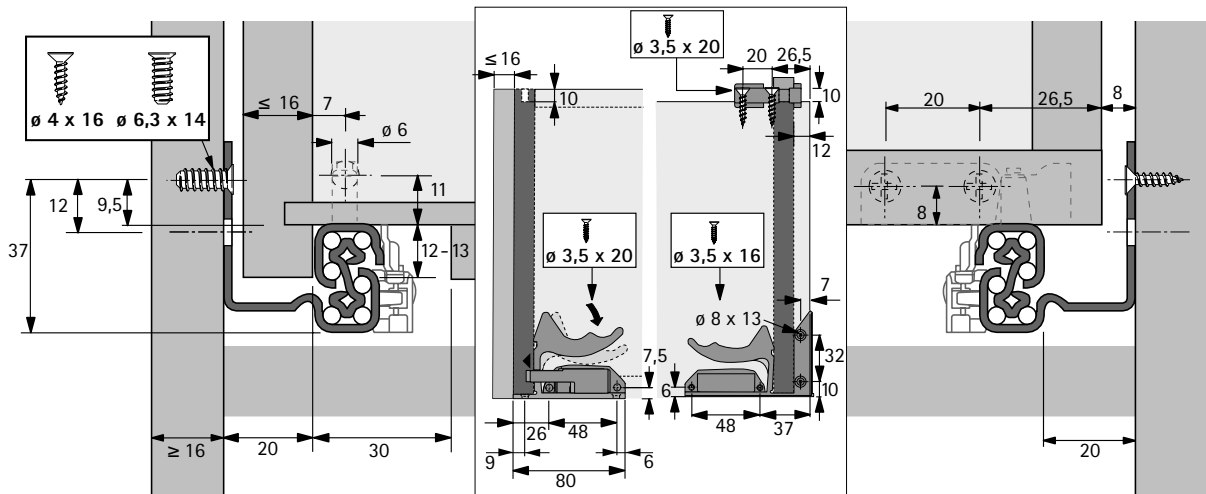

## Planning dimensions

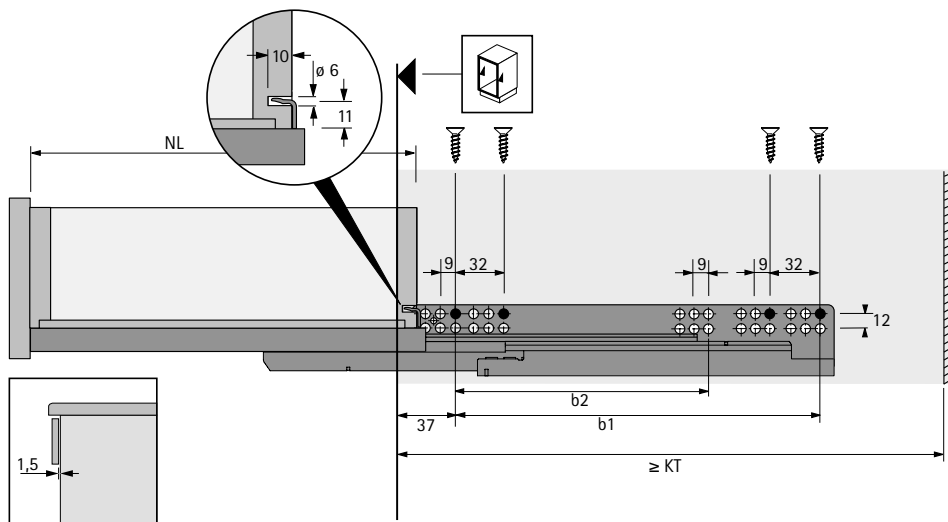

For technical information, see pages 12

# Drawer runners for wooden drawers

- ▶ Full extension runner Quadro V6 with Push to open
- ▶ Loading capacity 30 kg



- ▶ **Push to open** - the precision activating mechanism automatically opens the drawer in virtual silence - a light press is all it takes!
- ▶ Convenient slide on installation with catches and tool-less vertical adjustment
- ▶ Load capacity to EN 15338, Level 3
- ▶ Galvanised steel

## Quadro V6 with Push to open

Nominal length / drawer length NL mm	Minimum carcass depth KT mm	Hole spacing b1 mm	Hole spacing b2 mm	Order no.	PU
250	263	142		<b>9 111 235</b>	10 ea.
300	313	192		<b>9 111 236</b>	10 ea.
320	333	192		<b>9 111 237</b>	10 ea.
350	363	192		<b>9 111 238</b>	10 ea.
380	393	224		<b>9 111 239</b>	10 ea.
400	413	224		<b>9 111 240</b>	10 ea.
420	433	256		<b>9 135 996</b>	10 ea.
450	463	256		<b>9 111 241</b>	10 ea.
480	493	256		<b>9 135 997</b>	10 ea.
500	513	288	224	<b>9 111 242</b>	10 ea.
520	533	288	224	<b>9 111 243</b>	10 ea.
550	563	288	224	<b>9 111 244</b>	10 ea.

Using the mounting plug reduces drawer length (NL) by 10 mm.

## Catch for wooden drawers with grooved bottom panel (Quadro 25 and Quadro V6)



- ▶ For safely connecting the Quadro runner and wooden drawer without the need for tools
- ▶ Infinite height adjustment up to + 2 mm via a knurled wheel
- ▶ Plastic, black

Hinge side of cabinet	Order no.	PU
left	<b>9 144 830</b>	100 ea.
right	<b>9 144 841</b>	100 ea.



# Drawer runners for wooden drawers

- ▶ Full extension runner Quadro V6 with Push to open
- ▶ Loading capacity 30 kg

## Catch for pull-out shelves / wooden drawers with flush bottom panel Quadro V6



- ▶ For securely connecting Quadro runner and pull-out shelf / wooden drawer with flush bottom panel, including mounting, without the need for tools including plug
- ▶ For 16 - 19 mm thick pull-out shelves
- ▶ Plastic, black / white

Order no.	PU
0 075 808	5 pair

## Planning dimensions

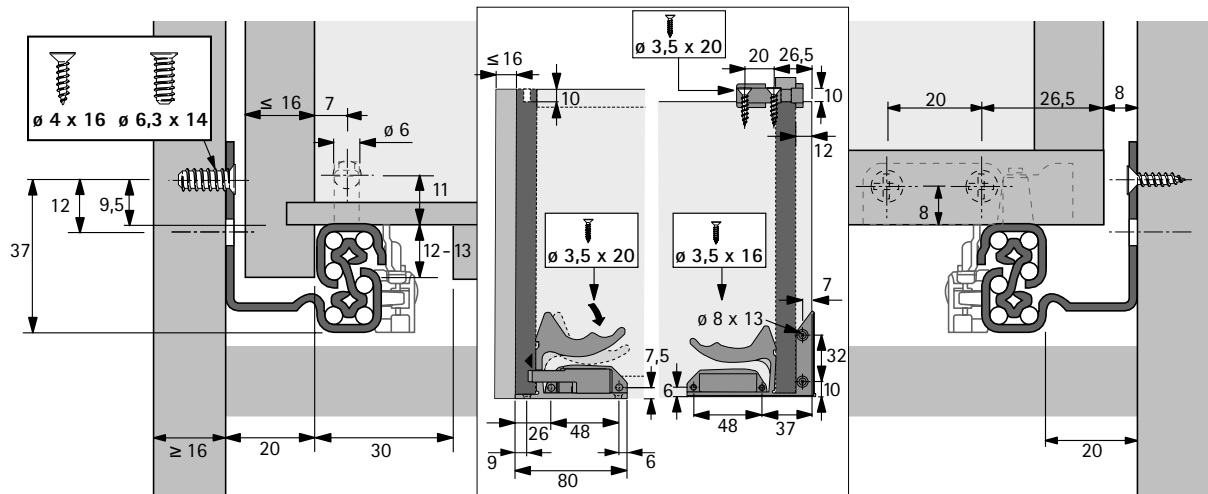

## Planning dimensions

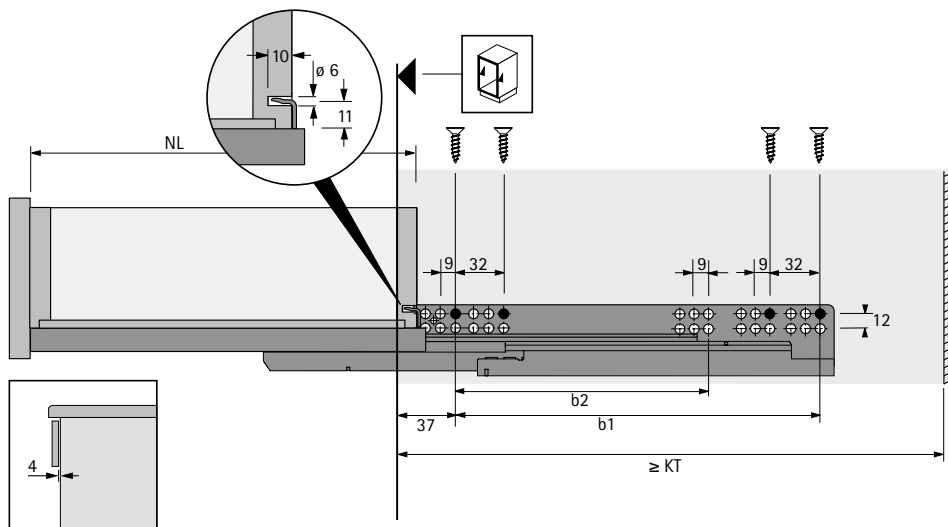

For technical information, see pages 12

# Drawer runners for wooden drawers

- ▶ Full extension runner Quadro V6+ with Silent System
- ▶ Loading capacity 50 kg



- ▶ **Silent System** - the integrated Silent System closes the drawer quietly and gently
- ▶ Convenient slide on installation with catches and tool-less vertical adjustment
- ▶ Load capacity to EN 15338, Level 3
- ▶ Galvanised steel

## Quadro V6+ with Silent System

Nominal length / drawer length NL mm	Minimum carcass depth KT mm	Hole spacing b1 mm	Hole spacing b2 mm	Order no.		PU
				left	right	
450	463	256	32	<b>9 127 811</b>	<b>9 127 812</b>	16 ea.
480	493	256	32	<b>9 127 813</b>	<b>9 127 814</b>	8 ea.
500	513	288	64	<b>9 127 790</b>	<b>9 127 801</b>	8 ea.
520	533	288	64	<b>9 127 786</b>	<b>9 127 787</b>	8 ea.
550	563	288	64	<b>9 127 788</b>	<b>9 127 789</b>	8 ea.

## Catch for wooden drawers with grooved bottom panel (Quadro V6+)



- ▶ For safely connecting the Quadro runner and wooden drawer without the need for tools
- ▶ Infinite height adjustment up to + 2 mm via a knurled wheel
- ▶ Plastic, black

Hinge side of cabinet	Order no.	PU
left	<b>9 117 483</b>	100 ea.
right	<b>9 117 485</b>	100 ea.
left / right	<b>9 117 492</b>	5 pair

# Drawer runners for wooden drawers

- ▶ Full extension runner Quadro V6+ with Silent System
- ▶ Loading capacity 50 kg

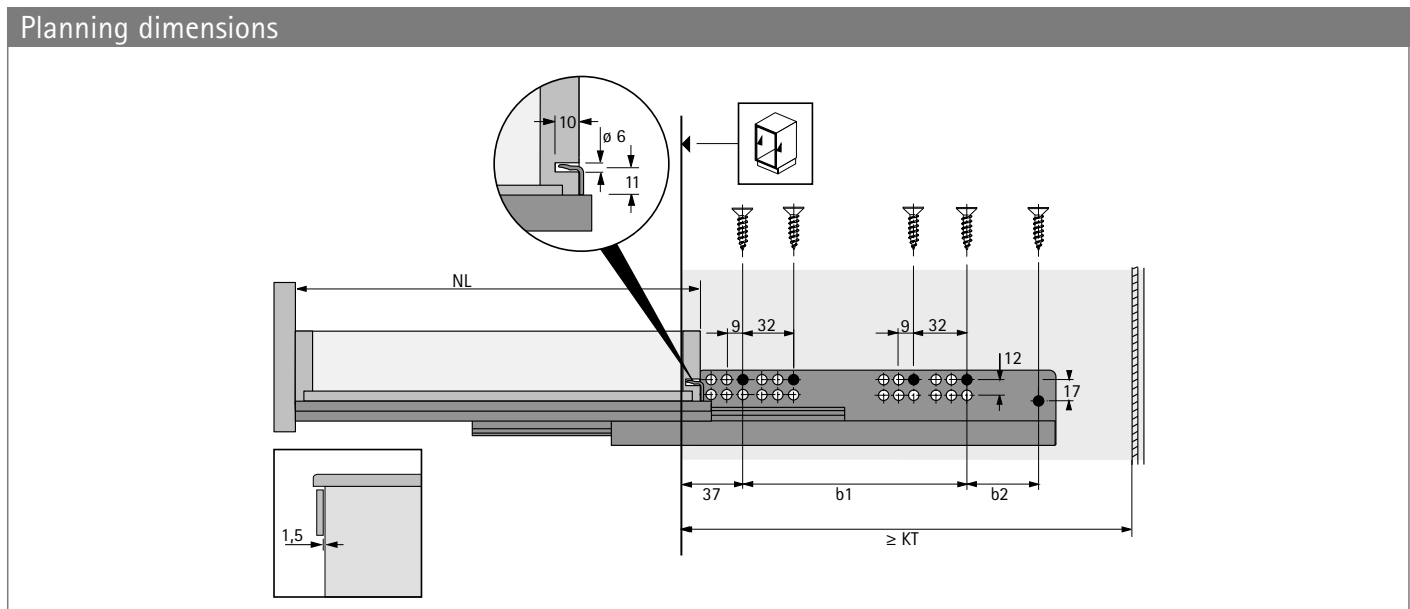
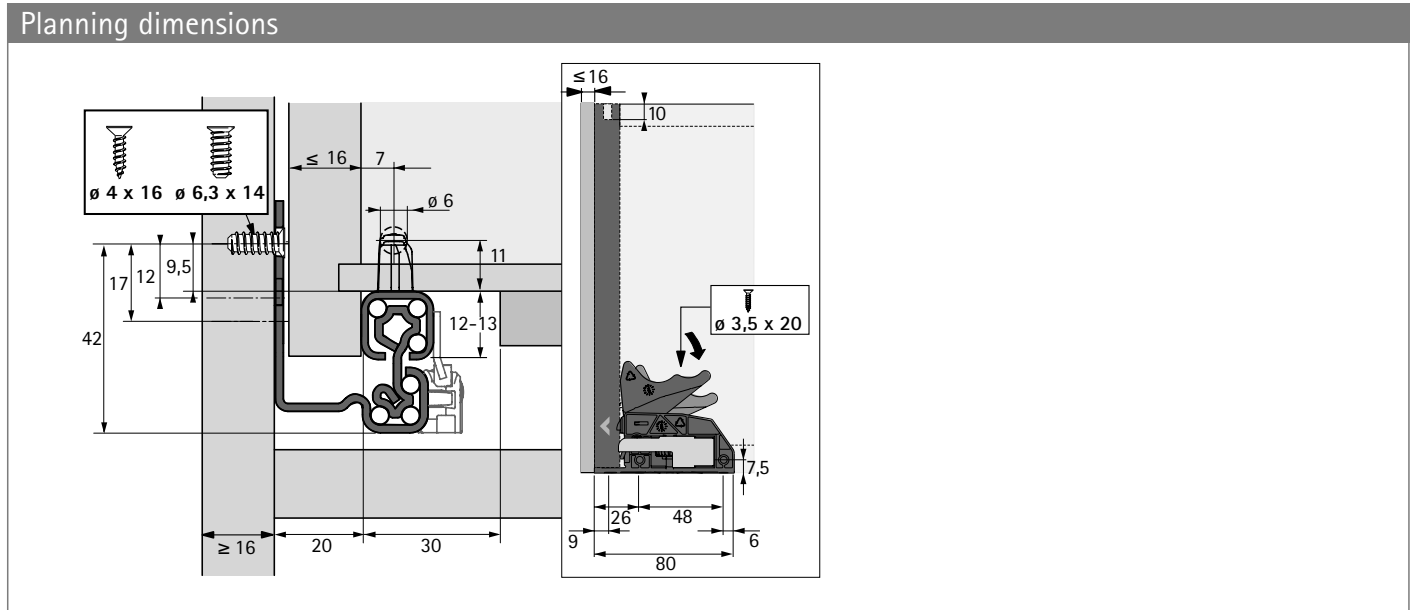

For technical information, see pages 12

- ▶ **Quadro**
- ▶ **Technical information**

## Quadro V6 full extension runner, slide on installation

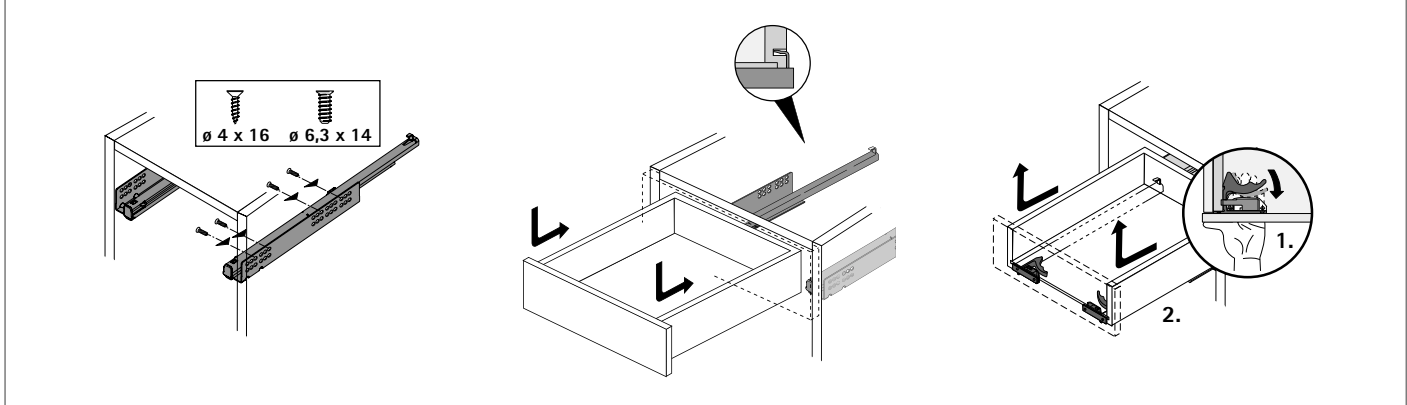

## Quadro V6+ full extension runner, slide on installation

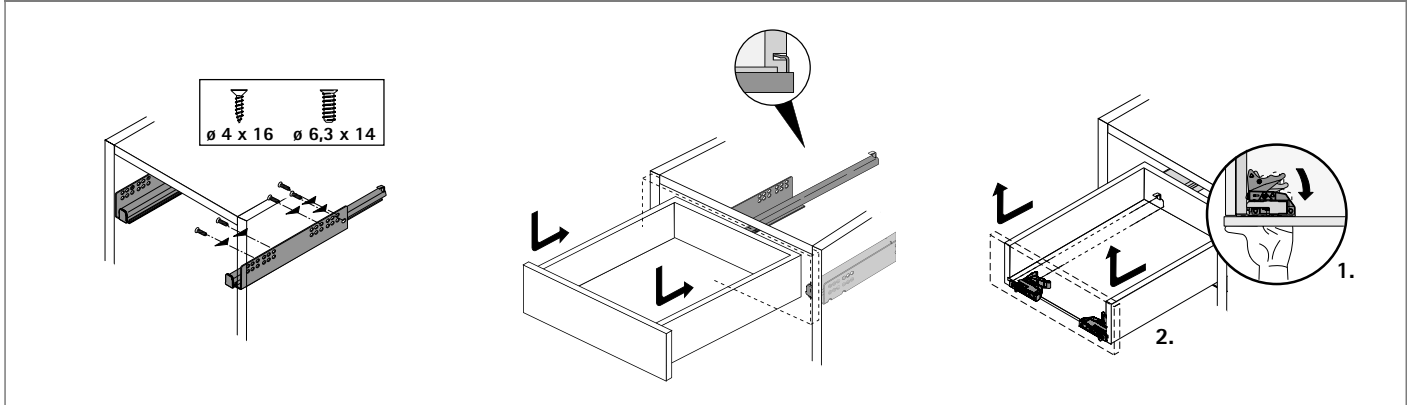

## Catch for wooden drawers with grooved bottom panel / Quadro V6 full extension runner

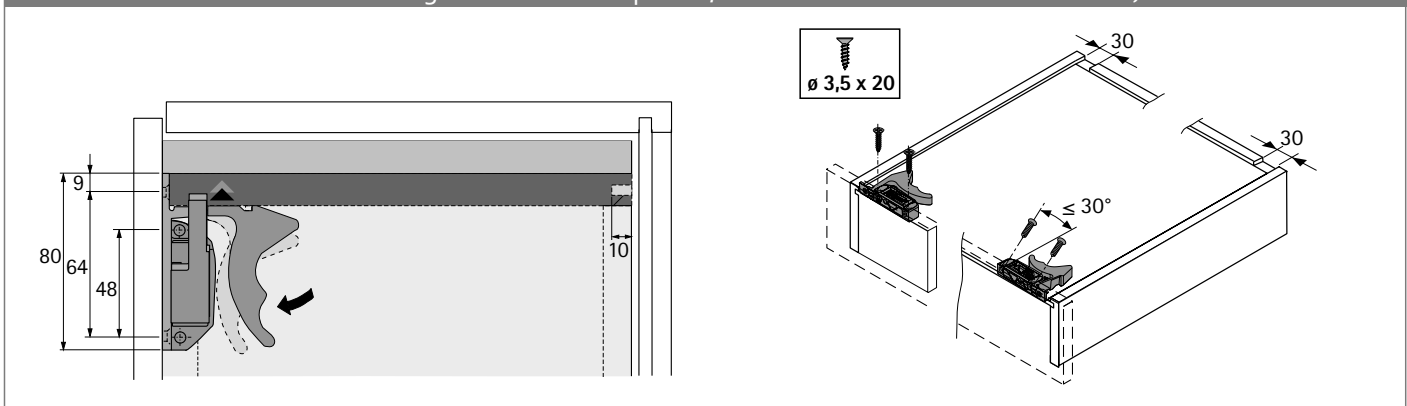

## Catch for wooden drawers with grooved bottom panel (Quadro V6+ full extension runner)

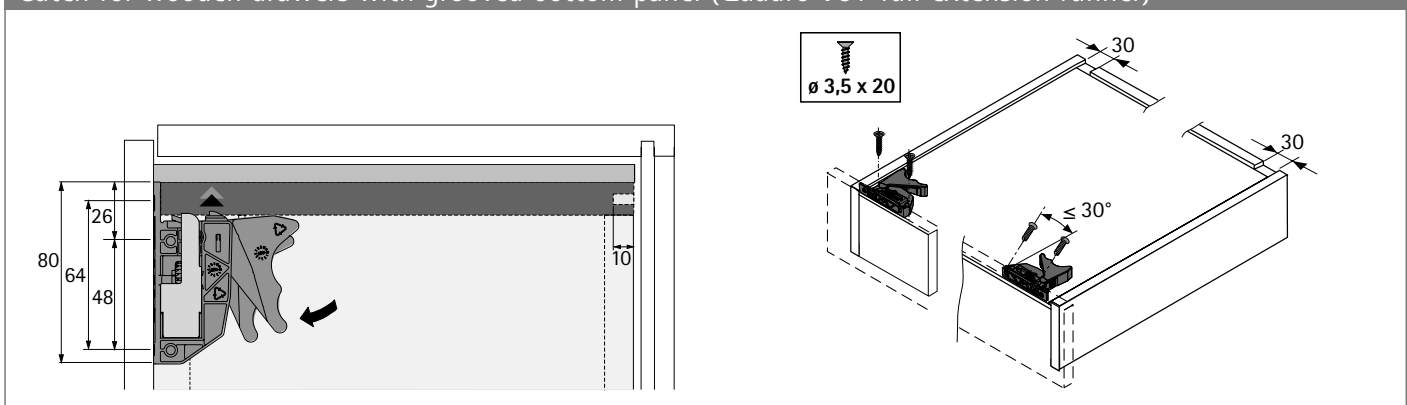

# Runner systems for wooden drawers: Quality that meets all the demands

## Quality that meets all the demands

The quality of drawer runners is subject to a process of continuous monitoring. Hettich fittings comply with the national and international quality standards of the markets our customers operate in. The diagrams below show some of the tests Hettich fittings are required to pass.

### Application area

Hettich drawer runners are suitable for use in living room, kitchen, bathroom and office furniture both in the home and business environment.

### Loading capacity and guards preventing unintentional detachment / removal

The loading capacity indicated (to DIN EN 15338) is understood to mean the weight of the drawer itself, including contents, in kg. The applicable level is shown on the product. Loading capacity relates

to a reference length of 500 mm. The loading capacity may vary for other nominal lengths. All Hettich drawer runners feature guards to prevent the drawer from rolling out and being removed unintentionally and meet the requirements of the impact test in a test frame to EN 15338. Used in the intended manner for furniture, these runners are suitable for use in living, kitchen and bathroom furniture to EN 14749 and for use in office furniture to EN 14073 and EN 14074. The maximum front panel height is governed in particular by material, drawer size and drawer runner. Testing is conducted on drawers with a 130 mm front panel height and pot-and-pan drawers with a 300 mm front panel height.

### Corrosion test

Hettich drawer runners satisfy the requirements on corrosion defined in EN 15338, 72-hour condensation water test to EN 6270.

## Wear test

The fully laden drawer must remain in proper working order after opening and closing it for a defined number of times at a defined test velocity.

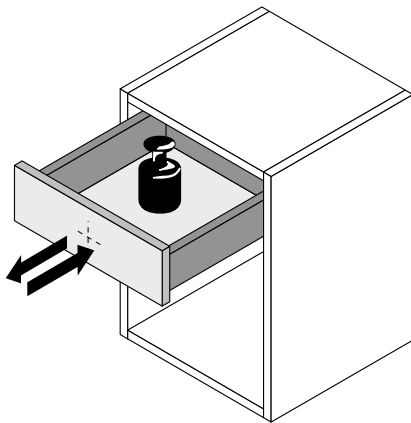

## Retention on opening test

The fully laden drawer is abruptly opened all the way several times at a defined test velocity.

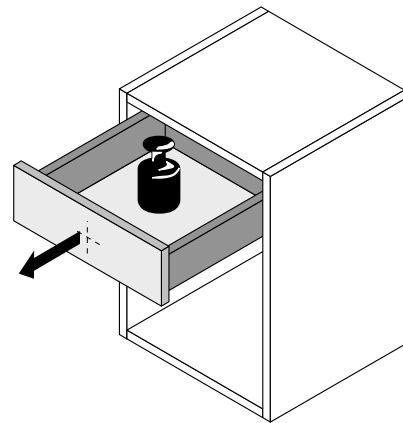

## Horizontal load test

Opened all the way, the fully laden drawer is additionally exposed to horizontal strain from a defined lateral force.

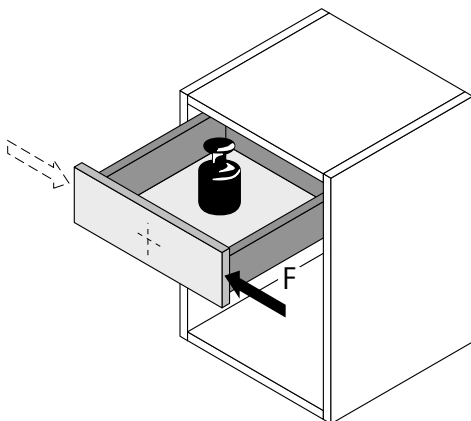

## Vertical strain test

Opened all the way, the fully laden drawer is additionally exposed to vertical strain from a defined eccentric force.

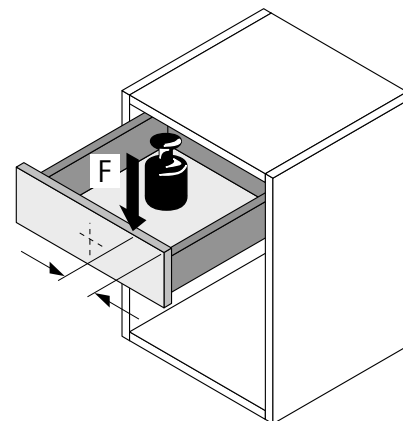

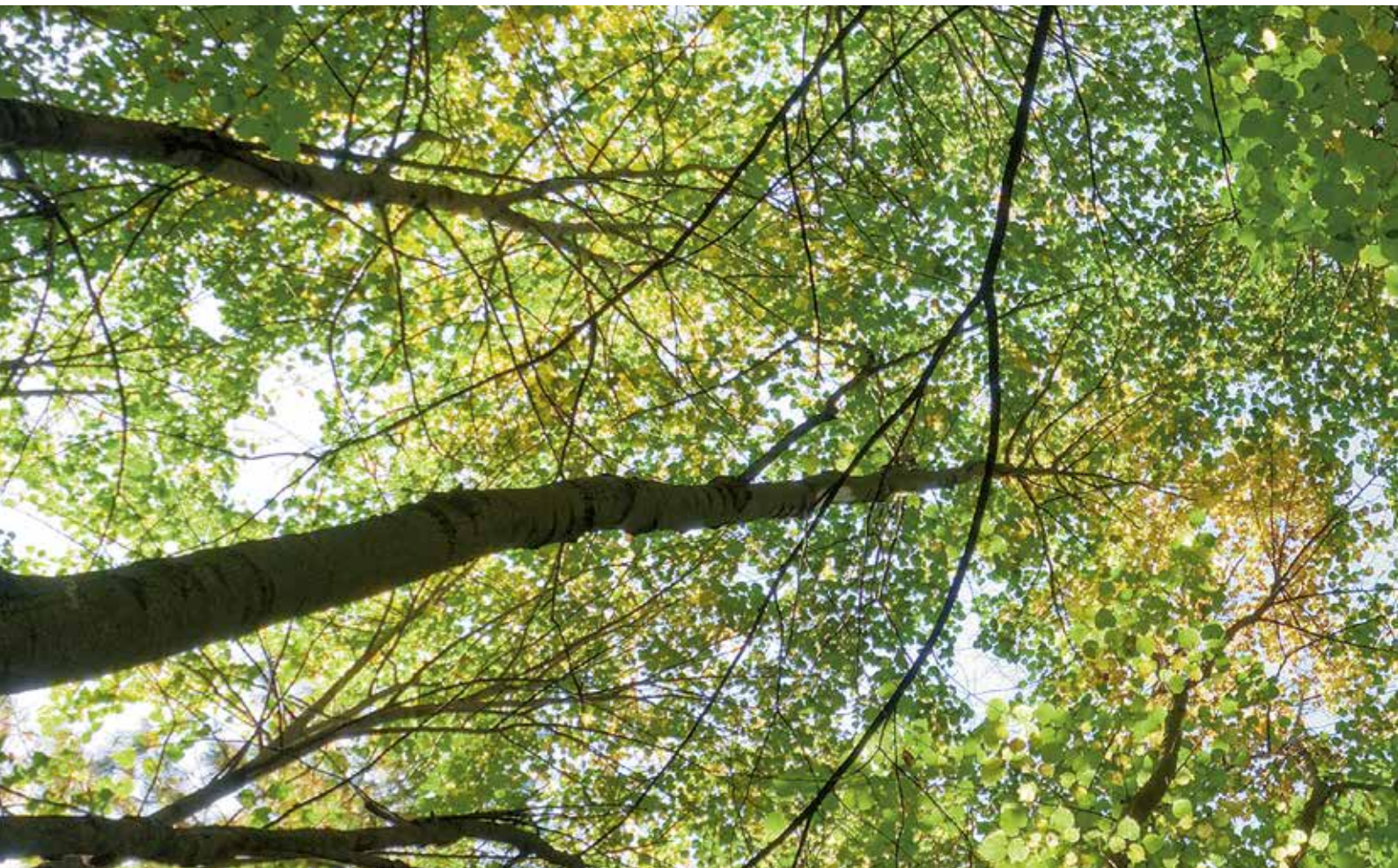

Hettich takes a responsibility for the world we live in. This awareness defines the strict policy of environmental management we practise. Our environmental officer has taken personal responsibility for these aspects throughout the group of companies over a period of many years. In addition, a separate environment committee has been established for each production site. We regard statutory provisions as minimum requirements. At significant sites we also implement the stringent EMAS Regulation. And we drive forward developments that in future will help to save even more raw materials and support the necessary endeavours towards sustainability.

### Hettich environmental management

In 1996 Hettich started introducing effective environmental management systems under the stringent EMAS Regulation (currently: EC Regulation No. 761/2001, including EN ISO 14001/2004). This not only enables us to improve our environmental performance on a broad front but also achieve a high level of safety which, not least, also benefits our customers. This is why we also require our suppliers to meet the necessary minimum standards of environmental protection, industrial safety, health care and social welfare. The results achieved in the drawer runner and drawer system product segment at the Kirchlengern operation illustrate the impressive effects these measures have and verifiably demonstrate our tireless endeavours to translate words into action:

Relief to the environment between 1997 and 2008:

Specific water consumption:	56 per cent
Specific power consumption:	21 per cent
Specific heat consumption:	84 per cent
Specific CO <sub>2</sub> emissions:	29 per cent





### Hettich standard for product materials

Hettich underpins its commitment by applying an internal standard for product materials. This ensures that every product – from production to disposal – satisfies all environmental requirements. Hettich products are durable. Appropriately foresighted, our rigorous standards are formulated to ensure that international legislation is met as well. This provides a reliable basis for marketing furniture worldwide.



### Zero energy building – Hettich Forum

The Hettich Forum building with its neutral energy balance is a shining example of future proof building design. Photovoltaic panels and solar collection system providing hot water as well as extensive roof greening and use of rain water underscore this building's overall sustainability concept in just the same way as the broad use of cellulose insulation material from recycled newspapers, highly efficient heat recovery and the bulb free lighting concept do.

With the Hettich Group having acquired European Commission GreenBuilding Partner status on 5 March 2009, the comprehensive approach demonstrated by the Hettich Forum has also convinced the adjudicating panel of the national "Green Building Award 2009". Hettich received the first prize to be presented in the "New Building" category.

Technik für Möbel



Let's move markets!

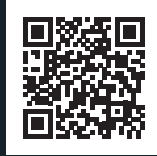

1512-015-Runner\_2203-HAU\_HNZ/en

Technik für Möbel

  
**Hettich**